

# OPERATOR'S MANUAL

## RKE 1500W SERIES POWER SUPPLY

SINGLE OUTPUT POWER SUPPLIES  
SINGLE PHASE, POWER FACTOR CORRECTED  
UNIVERSAL AC INPUT

KEPCO INC.  
An ISO 9001 Company.



MODEL  
**RKE 1500W SERIES**  
POWER SUPPLY

RKE 24-50K, RKE 48-32K

#### IMPORTANT NOTES:

- 1) The contents of this manual are protected by copyright. Reproduction of any part can be made only with the specific written permission of Kepco, Inc.
- 2) Data subject to change without notice.

©2005, KEPCO, INC  
P/N 228-1514



KEPCO, INC. • 131-38 SANFORD AVENUE • FLUSHING, NY. 11352 U.S.A. • TEL (718) 461-7000 • FAX (718) 767-1102  
email: [hq@kepcopower.com](mailto:hq@kepcopower.com) • World Wide Web: <http://www.kepcopower.com>

# TABLE OF CONTENTS

SECTION	PAGE
1. Introduction.....	1
1.1 Scope of Manual.....	1
1.2 Description.....	1
2. Specifications .....	1
3. Optical Coupler Output Alarm Circuit .....	5
4. Operation.....	6
4.1 Voltage Adjustment .....	7
4.2 Remote Voltage Control .....	8
4.3 Remote Turn On-Turn Off.....	8
5. Alarm Functions.....	8
5.1 Overvoltage And Overtemperature Protection.....	8
5.2 Overcurrent Protection .....	9
5.3 Fan Failure .....	9
5.4 Undervoltage .....	9
6. Load Connection .....	9
6.1 Connecting The Load .....	9
6.2 Parallel Connection .....	9
6.3 Series Connection .....	11
6.4 Preliminary Electrical Check .....	11
7. Fan Maintenance.....	12

## LIST OF FIGURES

FIGURE	TITLE	PAGE
1	Mechanical Outline Drawing Of The RKE 1500W Power Supply.....	4
2	Output Alarm Circuit Optically Isolated.....	5
3	RKE 1500W Power Failure Timing Diagram .....	5
4	Power Rating Vs. Temperature .....	6
5	Mounting Positions For The RKE 1500W Power Supply .....	6
6	Locations Of Operating Controls, Indicators and Terminals.....	7
7	Connections For Remote Voltage Control.....	8
8	Correct and incorrect Methods of Load Connection.....	9
9	Parallel Connection with Current Balancing .....	10
10	Parallel Connection, Master-Slave, Multiple Loads.....	10
11	Parallel Connection, Master-Slave, Single Load .....	11
12	Series Connection .....	11
13	Functional Checkout.....	12

## LIST OF TABLES

TABLE	TITLE	PAGE
1	Output Ratings and Specifications .....	1
2	Power Supply Ratings and Specifications .....	2

## 1. INTRODUCTION

### 1.1 SCOPE OF MANUAL

This Operator's Manual covers the installation and operation of the Kepco RKE 1500W Series of Switching Power Supplies. For service information, write directly to: Kepco Inc., 131-38 Sanford Avenue, Flushing, New York, 11352, U.S.A. Please state Model Designation and Serial Number of your RKE Power Supply. This information can be found on the nameplate of the unit.

### 1.2 DESCRIPTION

The Kepco RKE 1500W Series consists of two models of switching power supplies, each with a single output as shown in Table 1. Units include PFC (power factor correction) at the input and may be operated with a nominal 100V a-c to 240V a-c (input voltage range 85 to 265 Va-c), 50-60 Hz (input frequency range 47-66Hz). The RKE 1500W Series employs a light weight ferrite core with 135 KHz switching frequency. Regulation is provided by pulse width modulation. A power stage with two MOSFETS on each side of the primary winding, operating in the forward mode, provides a smooth isolated d-c output. A thyristor circuit prevents excessive turn-on current surge. Overvoltage protection and an isolated remote TTL ON-OFF control are provided. An LED "output voltage ON" light and an output voltage adjust trimmer are visible below the control terminals (left side of the case). Units are manufactured on a steel frame with a steel cover.

## 2. SPECIFICATIONS

Table 1 contains specifications and operating limits of individual RKE 1500W Series models. Table 2 contains specifications and operating limits common to all RKE 1500W Series Models. These specifications are at nominal input voltages at 25°C unless otherwise specified.

**TABLE 1. OUTPUT RATINGS AND SPECIFICATIONS**

MODEL RKE 1500W		24-50K	48-32K
Output Volts d-c		24V	48V
Adjustment Range		16.8-31.2	33.6-55.0
Voltage Setting		24 ±0.48	48 ±0.48
Maximum Output Ratings <sup>(4)</sup> (A,W)	85-132V a-c Input	Amps	37.5
		Watts	900
	170-265V a-c Input	Amps	50
		Watts	1200
Overcurrent Setting (Amps) <sup>(1)</sup>		55-65	33.6-36.8
Current Short Circuit		70	45
OVP Setting (Volts) <sup>(2)</sup>		32-35	56-60
Efficiency % typical	AC Input 100V	83	85
	AC Input 200V	85	88
Ripple & Noise <sup>(3)</sup> (mV, p-p)	ripple	200	300
	ripple noise	300	400
(1) Square type. After cause is removed, output voltage restored automatically.			
(2) When overvoltage is detected, output is shut OFF. Recovery is by removing power and reapplying power after approximately 30 seconds or by opening and reclosing the RC terminals .			
(3) Ripple and noise levels above are satisfied when conditions are 0 to 100% load, 0 to 65°C (load is derated from 50 to 65°C, see Figure 4), and bandwidth <= 100MHz.			
(4) See Figure 4 for power derating.			

**TABLE 2. POWER SUPPLY RATINGS AND SPECIFICATIONS**

CHARACTERISTIC	SPECIFICATION	CONDITION/NOTES
Input Voltage	85-265V a-c	(0 to 100% load, -10 to 65°C)
	110-370 Vdc	(0 to 100% load, -10 to 65°C)
Input Source Frequency	47-66 Hz.	(0 to 100% load, -10 to 65°C)
Input Current: (Maximum Load At 25°C with Nominal Output Voltage)	12A rms max.	100 - 120V a-c
	10A rms max. (8A rms max for 24V model)	200 - 240V a-c
Input Protection	A limiting resistor in series with a resistor fuse (and thyristor circuit) reduces start-up surge. Units are protected against shorts by an input fuse. Fuse value 25.0A At 250 Volts	
Input Surge cold start, interval > 30 sec ( First surge only, not including current flow into EMI filter)	15A typ., 20A max. first surge	100 - 120V ac
	30A typ., 40 max. first surge	200- 240 V ac
Leakage Current:	0.30mA typ., 0.75mA max.	120V a-c, 60Hz per IEC 950 and UL1950
	0.60mA typ., 0.75mA max.	240V a-c, 60Hz per IEC 950 and UL1950
Power Factor	0.99 typical	100V a-c, rated output
	0.95 typical	200V a-c, rated output
Transient Recovery excursion characteristic recovery time	±4% maximum	50% to 100% load, transient time >50μsec
	1 ms maximum	
Stabilization	Source Effect (min - max)	0.1% Typical, 0.2% Maximum
	Load Effect	1.0% Typical, 2.0% Maximum
	Temperature Effect	0.5% Typical, 1.0% Maximum
	Combined Effect	±1.6% Typical, ±3.2% Maximum
	Time Effect	0.2% Typical, 0.5% Maximum
		85 to 132 V a-c, 170 to 265V a-c
		0%-100% load change
		-10° to 65°C
		Envelope, Source, Load and Temperature
		(8 hours at 25°C)
Start-up Time	300 msec Typical, 450 msec Maximum	100V a-c
	250 msec Typical, 400 msec Maximum	200V a-c
Output Hold-up Time	10 msec Typical, 7 msec Minimum.	100V a-c
	10 msec Typical, 7 msec Minimum.	200V a-c
Overvoltage Protection	When the Power Supply goes into an overvoltage condition, the output is cut OFF. To restart (reset) the unit, it is necessary to remove the a-c input power, wait approximately 30 seconds, and then reconnect the a-c input power. An alternative is to open and then reclose the RC terminals (no waiting time required).	
Low Voltage Protection	If output falls to 60% of rated output for approximately 30 Seconds, the output is cut OFF. To restart (reset) the unit, it is necessary to remove the a-c input power, wait approximately 30 seconds, and then reconnect the a-c input power. An alternative is to open and then reclose the RC terminals (no waiting time required).	
Remote Control ON/OFF:	"High", 2.4V to 24V (or open), unit OFF- Fan Off ; "Low", 0.0V to 0.4V (or closed), unit ON. Source current is 1.6mA maximum at low level, and sink current is 1.0 mA maximum at high level. The ±RC terminals are isolated from the a-c input terminal and the DC output terminals. When remote ON/OFF is not in use, ±RC terminals must be shorted (use shorting link supplied) for unit to operate.	
Operating Temperature:	-10 to 65°C	(see Figure 4.)
Startup Temperature	-20 to -10°C	(see Figure 4.)
Storage Temperature:	-30°C to +75°C	

**TABLE 2. POWER SUPPLY RATINGS AND SPECIFICATIONS (CONTINUED)**

CHARACTERISTIC	SPECIFICATION	CONDITION/NOTES
Withstanding voltage : (at 15-35°C ambient, 10-85% relative humidity)	2000Va-c for 1 minute. Cutout current is 20mA	Between input and ground
	500Va-c for 1 minute. Cutout current is 100mA	Between output and ground
	3000Va-c for 1 minute. Cutout current is 20mA	Between input and output terminal
Insulation Resistance: (at 25°C, 65% relative humidity)	100 Megohms minimum (500Vdc)	Between output and ground, input and ground, and input and output,
Humidity:	10% to 95% relative humidity, noncondensing, Wet Bulb temperature $\leq$ 35°C	operating and non-operating
Vibration:	5-10 Hz., 10mm amplitude, 10-200 Hz., acceleration 64.3ft./s <sup>2</sup> (19.6M/s <sup>2</sup> ) (2g)	non-operating 1 hr. on each of 3 axes, sweep time 10 minutes
Shock:	Acceleration: 964.6ft./s <sup>2</sup> (294M/s <sup>2</sup> ) (30g), Pulse Duration: 11ms $\pm$ 5 msec	(non-operating, 1/2 sine pulse, three shocks on each axis, Power Supply is fixed on its bottom side)
Safety:	All units designed to meet UL1950, CSA Electrical Bulletin 22.2 No.950-95 (certified by UL), and TÜV Rheinland EN60950 (ambient temp. 50°C max.). Meets creepage and clearance requirements of DEN-AN Appendix A. RKE 1500W units are CE marked per the Low Voltage Directive (LVD), 73/23/EEC and 93/68/EEC. [The standards do not apply with DC input operation]	
EMC Emission - Conducted:	Designed to meet FCC Class B, VCCI-Class B, EN55011-B, EN55022-B	
EMC Emission - Radiated:	Designed to meet FCC Class B, VCCI-Class B, EN55011-B, EN55022-B	
EMC Emission - Input harmonics current:	Designed to meet EN61000-3-2	
EMC Immunity	Designed to meet EN50082-2	
EMC Radiated susceptibility:	EN61000-4-3 level 3	normal operation
EMC Conducted susceptibility:	EN61000-4-6 level 3	normal operation
ESD:	EN61000-4-2, level 4	normal operation
Electrical fast transient burst:	EN61000-4-4 level 3	normal operation
Surge withstand:	EN61000-4-5, level 4	No damage
Power Frequency Magnetic Field:	EN61000-4-8, level 4	normal operation
Voltage dips interruptions and variations	EN61000-4-11	normal operation
Dimensions:	3.62 in. (92 mm) x 4.72 in. (120 mm) x 9.33 in. (237 mm)	
Mounting:	Four No. M4 tapped holes on the sides and the bottom	
Maximum Screw Penetration:	0.24 in. (6 mm)	
Cooling:	Forced air flow - fan	
Frame Material/Cover Material:	Steel	
Weight	6.61 lbs, 3.0Kgs. maximum	

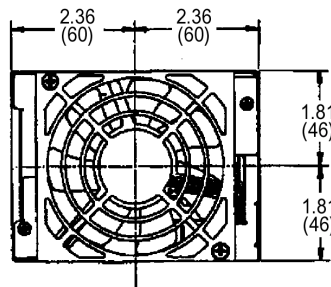

**NOTES:**

1. MAX PENETRATION OF M4 MOUNTING SCREWS IS 0.24 (6) FROM CASE SURFACE.
2.  $\pm 0.04$  ( $\pm 1$ ) TOLERANCE UNLESS OTHERWISE SPECIFIED.
3. DIMENSIONS ARE IN INCHES, DIMENSIONS IN BRACKETS ( ) ARE IN MILLIMETERS.
4. REFER TO FIGURE 4 FOR MOUNTING ORIENTATION.
5. IF THE POWER SUPPLY DOES NOT HAVE SAFETY STANDARD OR CE APPROVAL, THERE IS NO LABEL.

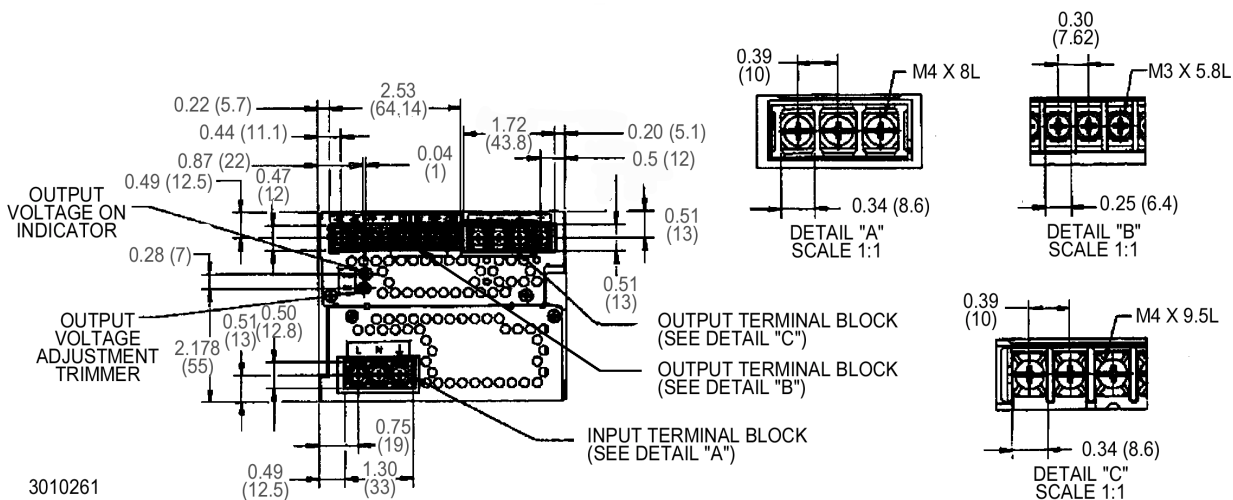
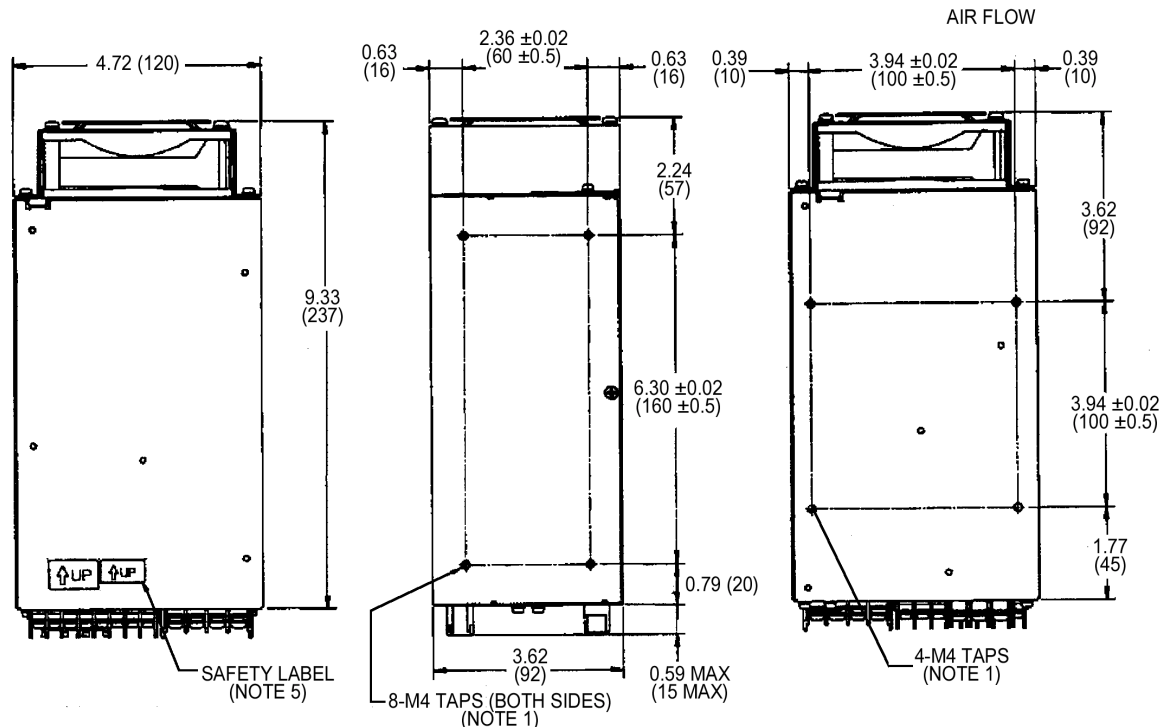

**FIGURE 1. MECHANICAL OUTLINE DRAWING OF THE RKE 1500W POWER SUPPLY**

### 3. OPTICAL COUPLER OUTPUT ALARM CIRCUIT

The default state of the alarm is logic low. The sink current for the optocoupler is 50mA maximum, the maximum collector to emitter saturation voltage is 0.40 Volts, and the collector to emitter voltage is 40 volts maximum. The PF terminals are isolated from the AC and DC output input terminals. Insulation resistance between the PF terminals and the AC input terminals is the same as the insulation resistance between the input and output. Insulation resistance between the PF terminals and the output terminals is the same as the insulation resistance between the output and ground.

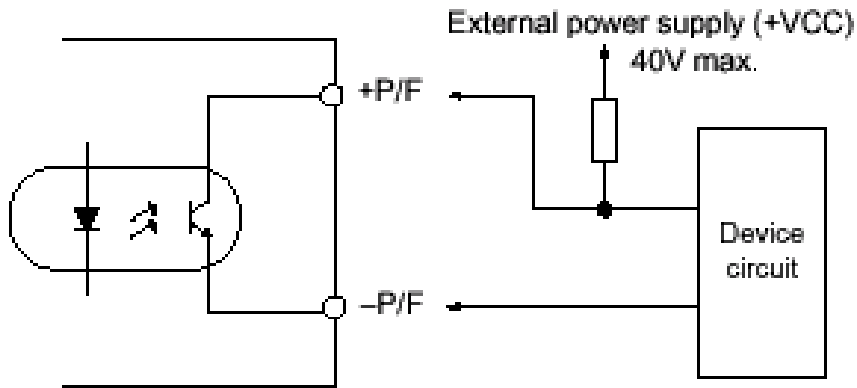

**FIGURE 2. OUTPUT ALARM CIRCUIT OPTICALLY ISOLATED**

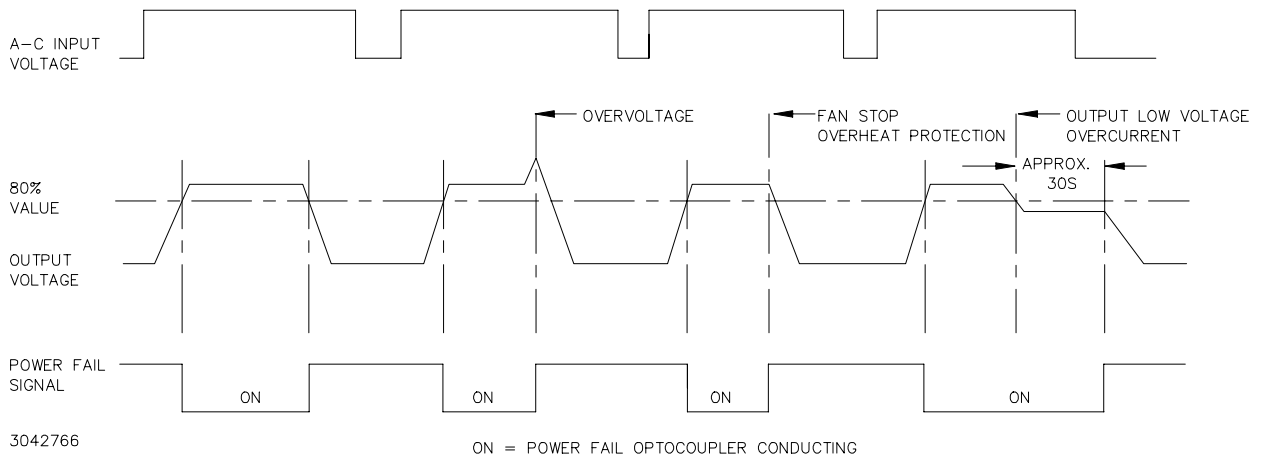

**FIGURE 3. RKE 1500W POWER FAILURE TIMING DIAGRAM**

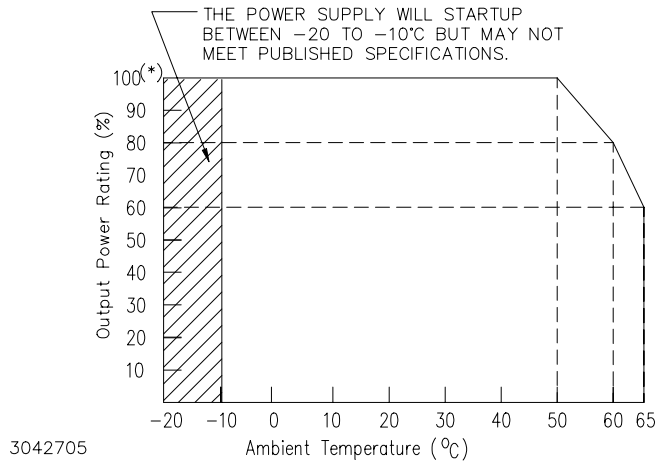

**FIGURE 4. POWER RATING VS. TEMPERATURE**

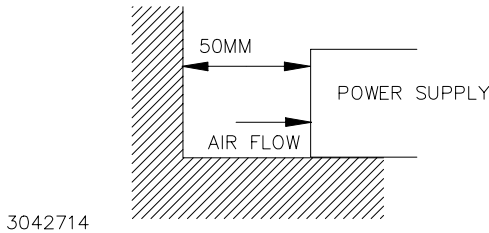
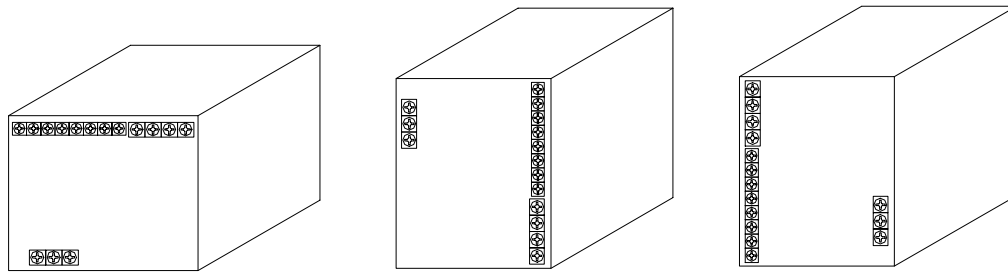

NOTE:  
INSTALL POWER SUPPLY IN WELL-VENTILATED AREA  
WITH FAN AT LEAST 50MM FROM OTHER EQUIPMENT.

**FIGURE 5. MOUNTING POSITIONS FOR THE RKE 1500W POWER SUPPLY**

**4. OPERATION**

Figure 6 shows the location of all operating controls and input/output terminals followed by an explanation of each. The unit is shipped with shorting links installed connecting the following terminals: +RC to -RC and REF to RV

**NOTE: If remote ON/OFF is not being used, ±RC terminals must be connected (use shorting link supplied) for unit to operate.**



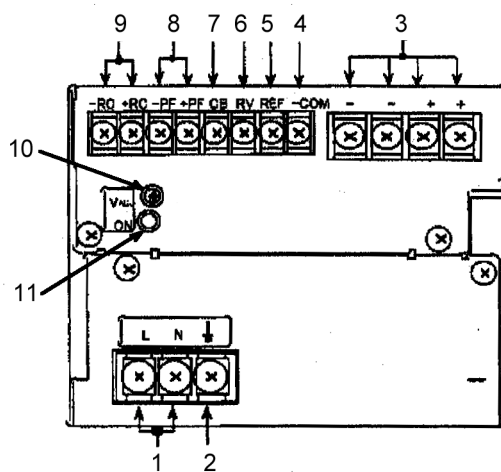

1. A-C Input (L, N)
2. Frame Ground (earth)
3. D-C Output (+, -)
4. Signal Common (-COM)
5. Reference Voltage (REF)
6. Output Voltage Adjust (RV)
7. Current Balance (CB)
8. Power Failure (+PF, -PF)
9. Remote ON-OFF (+RC, -RC)
10. Output Voltage Trim Adjust (Vadj)
11. Output Voltage On indicator (green)

NOTE Unit is shipped with shorting links (not shown) connecting +RC to -RC (see PAR. 4.3) and REF to RV (see PAR. 4.2)

**FIGURE 6. LOCATIONS OF OPERATING CONTROLS, INDICATORS AND TERMINALS**

1. AC input terminals (L, N): Connect to AC, 100 to 240V, input line.
2. Frame ground terminal: Connect to earth ground. This terminal is connected to the case.
3. DC output terminals (+, -): Connect to load (see Figure 8).
4. Signal Common (-COM): Provides return for REF and RV signals
5. Reference Voltage terminal: With the use of the REF terminal (together with the RV terminal) all the output voltages of slave power supplies can be controlled by one voltage adjustment of a master power supply (normally it is shorted with a metal shorting link to the RV terminal).
6. Remote voltage adjustment terminal (RV): This terminal (together with the REF terminal) is used for remotely controlling output voltage (see PAR. 4.2).
7. Current balance terminal (CB): This terminal is used when several power supplies are connected in parallel (see PAR. 6.2).
8. Power failure terminal (+PF, -PF) - These terminals output an open logic signal if output voltage drops to 80 % or lower of a set voltage, or if output voltage is shut down due to overvoltage or overcurrent protection, fan speed failure, or overheating. (see Figure 3).
9. Remote ON-OFF terminals (+RC, -RC): Output is turned ON-OFF by opening-shorting the RC terminals (output OFF when open). RC terminals are isolated from input and output terminals. Normally,  $\pm$ RC terminals are shorted with a metal shorting link (see PAR. 4.3).
10. Output voltage adjustment trimmer (V.ADJ): Adjusts output voltage.
11. Output ON indicator: This green LED lights when output voltage is present.

#### 4.1 VOLTAGE ADJUSTMENT

Output voltage can be manually adjusted with the voltage adjustment control, Vadj (see Figure 6). To adjust voltage, first place the unit under an operating load, then monitor the (+) and (-) output terminals with a precision voltmeter and turn the voltage control to the desired operating value. Refer to Table 1 for the recommended Adjustment Range of all the RKE 1500W Models

## 4.2 REMOTE VOLTAGE CONTROL

The unit is shipped with a shorting link in place between RV and REF terminals. Removal of this link allows the output voltage to be adjusted by either a trimmer pot (resistance) or by an external variable voltage source across the RV terminal and COM terminal.

**NOTE:** If remote voltage control is not implemented, the shorting link between RV and REF must be in place

It is possible that the overvoltage protection may be triggered if the output voltage is decreased to a low level very quickly when the power supply is at a low load condition.

**RESISTANCE:** Use a shielded wire 6.6 feet (2M) maximum in length, for connection (of REF, RV, and -COM terminals) to the trimmer control. Connect the external trimmer as shown in Figure 7 (A). Suggested value for the trimmer control is 5K ohms. With the external trimmer control at its maximum clockwise position, set the output voltage to the desired maximum value by adjusting  $V_{adj}$  clockwise. The output voltage adjustment range is from 70 to 130% for the 24V model and from 70 to 115% for the 48V model.

**VOLTAGE.** By adjusting an external 3.5 to 6.5V voltage source the 24V model can be adjusted from 70 to 130% of the nominal output. By adjusting an external 3.5 to 5.75V voltage source the 48V model can be adjusted from 70 to 115% of the nominal output. Remove the shorting link between the REF and RV terminal. Connect the voltage source across the RV and -COM terminals as shown in Figure 7 (B).

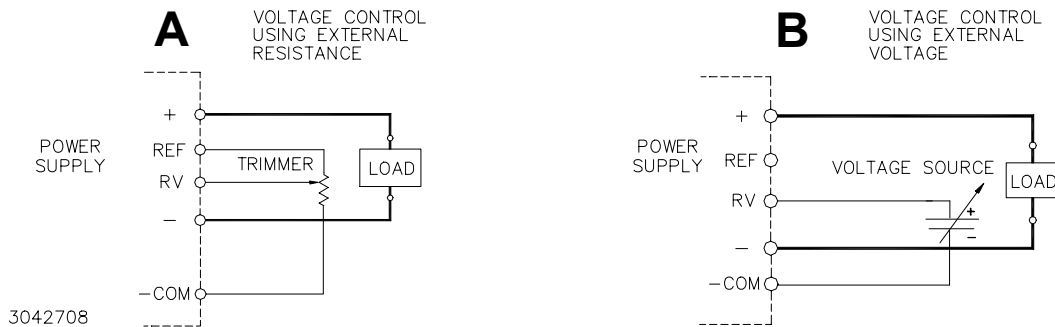

**FIGURE 7. CONNECTIONS FOR REMOTE VOLTAGE CONTROL**

## 4.3 REMOTE TURN ON-TURN OFF

When power is ON at the source, the output may be turned ON or OFF with the remote control feature using the  $\pm RC$  terminals (see Figure 6). These terminals accept a logic level (2.4V to 24V "high" and 0.0 to 0.4V "low"), or a contact closure. When the  $\pm RC$  terminals are open, using either a mechanical switch or a high level logic signal, the RKE 1500W output is cut OFF. When the RC terminals are shorted, the output returns to within specifications. At low level logic, the maximum source current is 1.6mA and at high level the sink current is 1.0mA. The RC terminals must remain shorted if remote ON-OFF is not used. The RC terminals are isolated from both the AC input and DC output terminals.

## 5. ALARM FUNCTIONS

### 5.1 OVERVOLTAGE AND OVERTEMPERATURE PROTECTION

When the output voltage of the RKE 1500W Power Supply increases beyond the specified values (see Table 1), the output is cut OFF and the fan turns OFF. To restart (reset) the unit, remove AC input power, wait approximately 30 seconds, then reconnect AC input power; or open the RC terminals and then reclose the terminals.

When the internal temperature of the RKE 1500W Power Supply increases beyond the specified values (see Table 1), the output is cut OFF and the fans turn OFF. The restart cycle (Power ON)

should not begin until the temperature returns to within specifications. To restart (reset) the unit, remove AC input power, wait 40 seconds, then reconnect AC input power. The power supply cannot be reset using the remote ON-OFF feature unless the power supply is first shut down for 40 seconds and then turned on again.

The alarm circuit is a diode transistor optical coupler. The transistor is normally conducting. When the alarm is activated, the transistor cuts off and the collector emitter circuit is open (see Figure 2)

## 5.2 OVERCURRENT PROTECTION

The output characteristic of the power supply is a square type, and the unit is set to shut down if output current exceeds specifications (see Table 1) for more than 30 seconds. To restart (reset) the unit, remove AC input power, wait 40 seconds, then reconnect AC input power. or open the RC terminals and then reclose the terminals. (see PAR. 4.3).

## 5.3 FAN FAILURE

A cutoff of the fan supply voltage causes the output to shut down and the fans to turn OFF. Fan failure and all the other protection circuit operations are indicated by an open circuit across the ( $\pm$ ) PF terminals. To restart (reset) the unit remove the AC input power, wait 40 seconds, then reconnect AC input power; or open the  $\pm$ RC terminals and then reclose the terminals. If fan rotation is out of specification the power supply will not recover

## 5.4 UNDERVOLTAGE

If the output voltage of the power supply falls below 60 percent of the rated voltage for 30 seconds, the power supply shuts down and the power failure alarm (see PAR. 3.) will go to the high logic state. To restart (reset) the unit remove the AC input power, wait 40 seconds, then reconnect AC input power; or open the  $\pm$ RC terminals and then reclose the terminals.

## 6. LOAD CONNECTION

### 6.1 CONNECTING THE LOAD

The load is connected across DC output (+) and (-) terminals (see Figure 8).

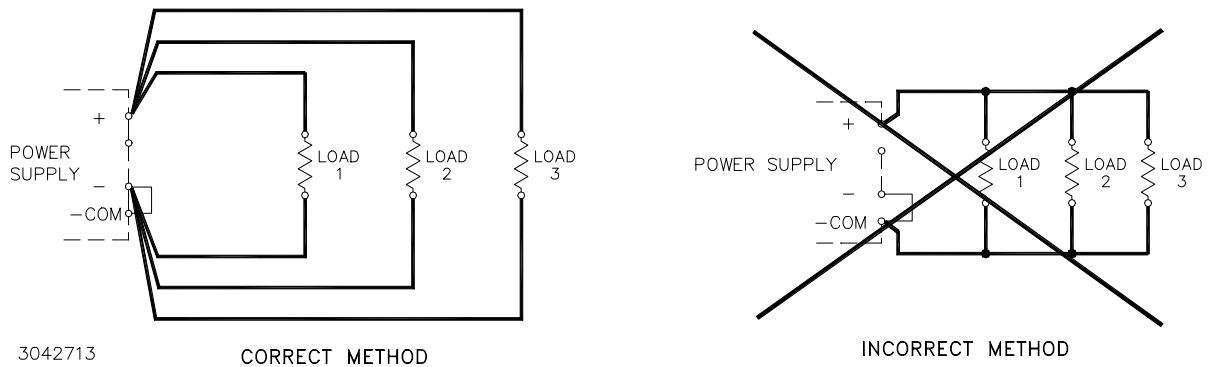

**FIGURE 8. CORRECT AND INCORRECT METHODS OF LOAD CONNECTION**

### 6.2 PARALLEL CONNECTION

RKE 1500W Power Supplies can be connected in parallel (with or without N+1 redundancy). The impedance of the load wires between each power supply and load should be the same.

Figure 9 illustrates connection of up to four (maximum) power supplies in parallel. Output current for a parallel connection operating into a single load is equalized by connecting the CB terminals as shown. For a single remote ON-OFF signal to turn off all parallel-connected units, connect together all +RC terminals and connect together all -RC terminals (see PAR. 4.3).

The current equalization with up to four RKE 1500W units in parallel should be within 20 to 90% of the total output current rating. The output voltage of any Power Supply individually must be within 2% maximum of the other power supply output voltage setting. The expected current sharing is such that the output current variation for each power supply is less than or equal to 10% of each power supply rated output current.

**N+1 Redundancy.** An N+1 system requires one additional power supply than necessary to supply the load. If one of the parallel-connected units fail, the others will continue to provide power to the load without down time. For redundancy, add isolation diodes as shown in Figure 9.

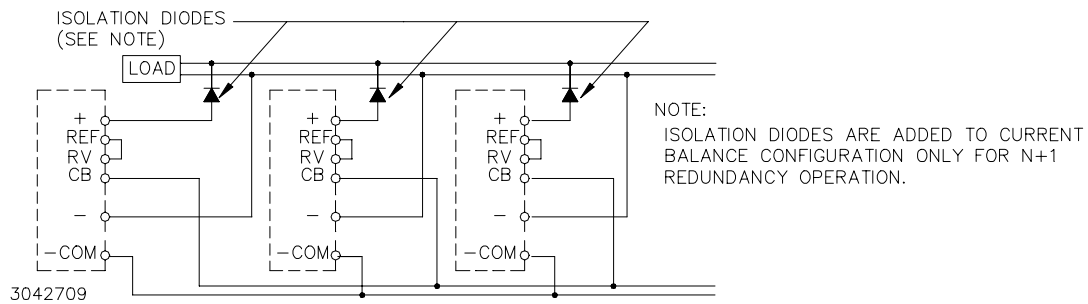

**FIGURE 9. PARALLEL CONNECTION WITH CURRENT BALANCING**

### 6.2.1 CURRENT BALANCING

For parallel operation (see Figures 9 or 11) the conditions for current equalization are:

$$\frac{\text{Maximum Voltage} - \text{Minimum Voltage}}{\text{Rated Voltage}} = 2\% \text{ variation of output voltage in each power supply}$$

The maximum output current: Rated output current of each power supply x (number of power supplies) x (20 to 90 percent).

Variation of output current < ±10 % of each rated output current

### 6.2.2 MASTER-SLAVE CONFIGURATIONS

Master-slave operation allows the output voltage of all the power supplies connected in parallel to be adjusted at the same time by using the Vadj control on the designated master power supply.

#### 6.2.2.1 MASTER-SLAVE, MULTIPLE LOADS

Figure 10 shows the master-slave connection of three power supplies in parallel, each having an independent load, with output voltage controlled by the Vadj control of the master power supply. Use shielded wire for connections to RV terminals.

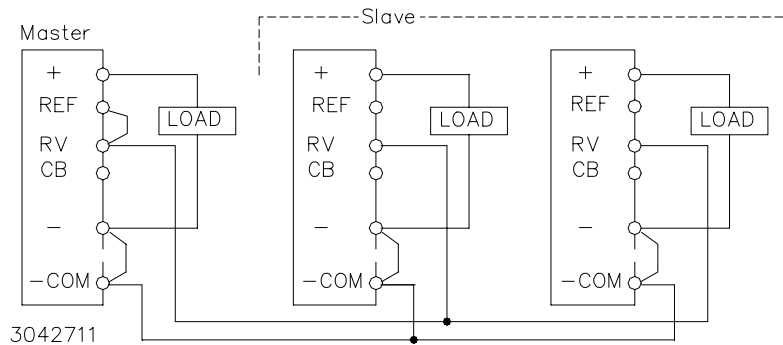

**FIGURE 10. PARALLEL CONNECTION, MASTER-SLAVE, MULTIPLE LOADS**

### 6.2.2.2 MASTER-SLAVE, SINGLE LOAD

Figure 11 shows the connection of three power supplies in parallel to a single load. The output voltage of all power supplies is controlled by  $V_{adj}$  of the master. Current balancing is implemented to equalize the load current (see PAR. 6.2.1). NOTE: Use shielded wire for connections to RV terminals. Match impedance of load wires between each power supply and load by using the same wire lengths and wire sizes.

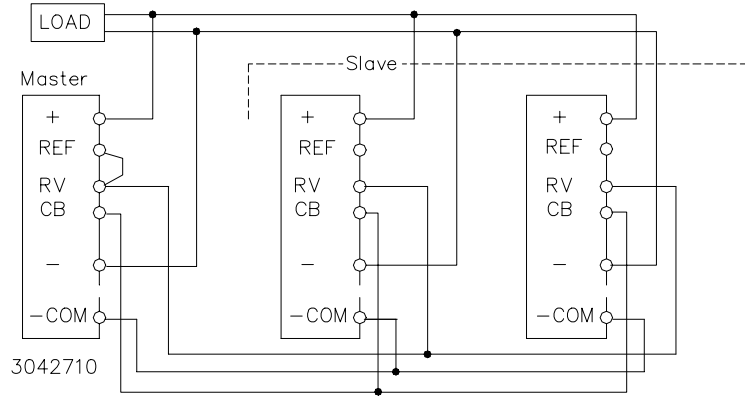

FIGURE 11. PARALLEL CONNECTION, MASTER-SLAVE, SINGLE LOAD

### 6.3 SERIES CONNECTION

Units may be connected in series to obtain higher voltages. When a number of power supplies are operating in series, the current rating is to be limited to the rating of the power supply with the lowest rating. Each Power Supply in series should be protected by a diode connected in parallel with the output as shown in Figure 12. The diode protects against reverse voltages. It should be rated for typically,  $V_{REVERSE} \geq 2 \times \Sigma V_{OUT}$  of the series connection,  $I_{FORWARD} \geq 2 \times I_{OUT}$  of the series connection).

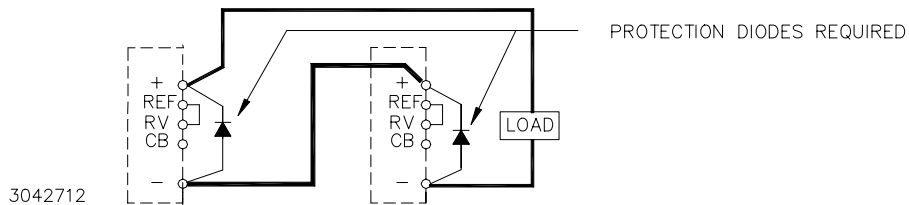
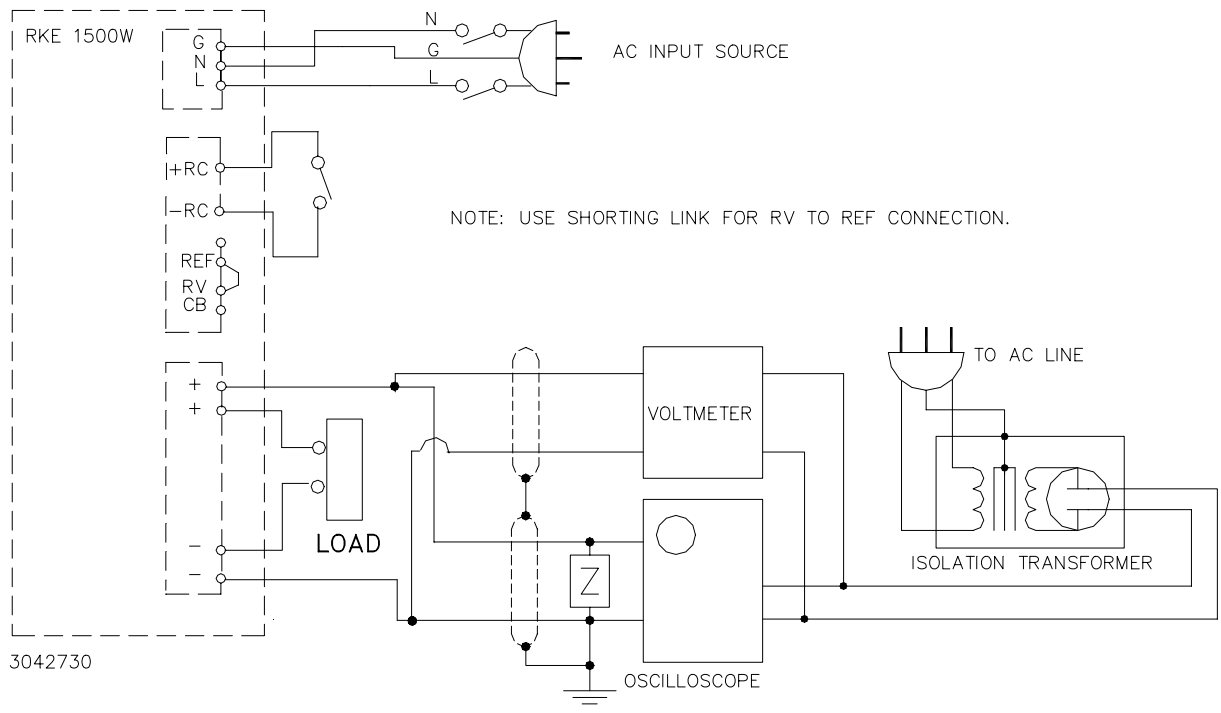

FIGURE 12. SERIES CONNECTION

### 6.4 PRELIMINARY ELECTRICAL CHECK

Connect an adjustable load across the power supply DC output terminals, on the right side of the front panel (see Figure 6). The load must have a dissipation rating of at least 3000 Watts. Connect a voltmeter and an oscilloscope across the power supply DC output (+) and (-) terminals. The oscilloscope must be isolated from the source and grounded at the load. Use an isolation transformer between the test equipment and the AC input power (see Figure 13).

Connect the AC input power to the line, neutral and ground terminals (see Figure 6). Turn source power on and check the output voltage both with and without load. The output voltage can be adjusted within the published range by using the front panel voltage control trimmer  $V_{adj}$ .



**FIGURE 13. FUNCTIONAL CHECKOUT**

**7. FAN MAINTENANCE**

Under most conditions the fan requires no maintenance. Do not use the fan in an environment of high temperature and high humidity that exceeds the temperature and humidity limits given in the Power Supply Specifications (see Table 2). Avoid an environment where corrosive gas may be present. If the Power Supply is used in an open or dirty area, a filter should be installed on the air intake side of the fan to prevent the inflow of dust particles. If the Power Supply is used in briny air care should be taken to keep the salt from entering the Power Supply.

You must register your product to comply with the terms of the warranty. Either fill out the form below and mail or fax to Kepco, or for rapid on-line registration go to:

<http://www.kepcopower.com/warranty.htm>

**PRODUCT PURCHASED:**

Model Number) \_\_\_\_\_

Serial Number \_\_\_\_\_

**PURCHASE INFORMATION:**

Date Purchased: \_\_\_\_\_

Date Received: \_\_\_\_\_

**REQUEST ADDITIONAL INFORMATION**

Send complete Catalog

Have Sales Engineer Call

Contact via:  E-Mail  Telephone  Fax  S-mail

**REGISTER TO:**

Registered by: \_\_\_\_\_

Company Name: \_\_\_\_\_

Street: \_\_\_\_\_

City: \_\_\_\_\_

State: \_\_\_\_\_

Country: \_\_\_\_\_

Zip: \_\_\_\_\_

E-mail: \_\_\_\_\_

FAX: \_\_\_\_\_

Phone: \_\_\_\_\_

**WHAT INFLUENCED YOUR CHOICE OF THIS POWER SUPPLY?**

Previous Experience (which Kepco Models do you have?) \_\_\_\_\_

\_\_\_\_\_

\_\_\_\_\_

\_\_\_\_\_

Magazines (which ones?) \_\_\_\_\_

\_\_\_\_\_

Trade Shows (which ones?) \_\_\_\_\_

Directory? \_\_\_\_\_

Kepco Catalog or Brochure? \_\_\_\_\_

Sales Representative?

Web Site

Other (please explain): \_\_\_\_\_

What products would you like to see Kepco make?

\_\_\_\_\_

\_\_\_\_\_

\_\_\_\_\_

CUT HERE

*Kepco 5 Year Warranty*

This is to certify that we, KEPCO, INC., (hereinafter called "Company"), Flushing, NY 11352 USA, warrants for a period of FIVE YEARS, this instrument known as:

MODEL: \_\_\_\_\_

SERIAL NO. \_\_\_\_\_

The Company's products are warranted for a period of five years from date of delivery to be free from defects in materials and workmanship and to conform to the specifications furnished or approved by the Company. Liability under this warranty shall be limited to the repair or replacement of any defective product at Company's option.

If any defect within this warranty appears within the warranty period, the Purchaser shall promptly notify the Company in writing. No material will be accepted for repair or replacement without written authorization of the Company.

Upon such authorization, and in accordance with instructions of the Company, parts or materials for which replacement is requested shall be returned to the Company for examination, with shipping charges prepaid by the Purchaser. Final determination as to whether a product is actually defective rests with the Company.

This warranty does not extend to any product which has been subjected to misuse, neglect, accident, improper installation, or use in violation of instructions furnished by the Company. The warranty does not extend to, or apply to, any unit which has been repaired or altered outside of the Company's factory by persons not expressly approved by the Company.

THE WARRANTY HEREIN CONTAINED IS IN LIEU OF AND EXCLUDES ALL OTHER WARRANTIES, EXPRESS, IMPLIED OR STATUTORY, INCLUDING WITHOUT LIMITATION THE WARRANTY OF MERCHANTABILITY.

**THIS KEPCO PRODUCT IS WARRANTED FOR FIVE YEARS!**

KEPCO, INC. • 131-38 SANFORD AVENUE, FLUSHING, NY 11352 USA • Tel. 718-461-7000 • Fax. 718-767-1102  
E-mail: [hq@kepcopower.com](mailto:hq@kepcopower.com) • URL: <http://www.kepcopower.com>



FOLD HERE

Please  
place  
stamp  
here

# **KEPCO, INC.**

131-38 SANFORD AVE.  
FLUSHING, NY 11352 USA

CUT HERE